

# Cable Ties

## Standard Fluorescent

- |                                 |  |
|---------------------------------|--|
| • <b>Material:</b>              | UL approved Nylon 66, 94V-2.   |
| • <b>Feature:</b>               | High tensile strength with low insertion force.<br>Excellent resistance to weathering and ageing.<br>Suitable for a multitude of uses in various industries. |
| • <b>Application:</b>           | Self-locking for fast and easy application.  |
| • <b>Operating Temperature:</b> | -40°C to +85°C.  |

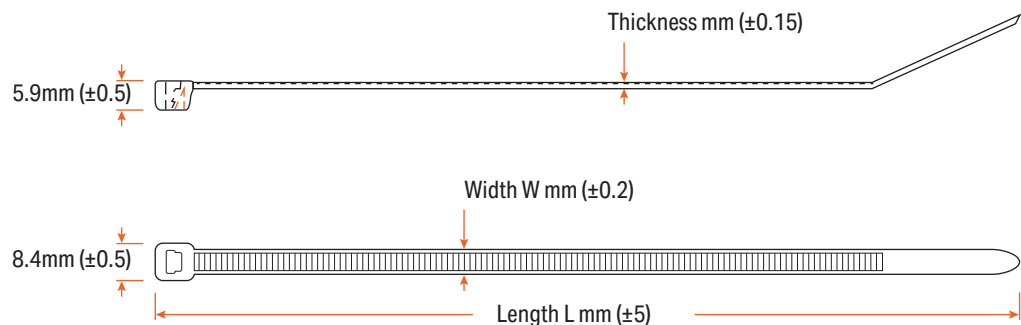
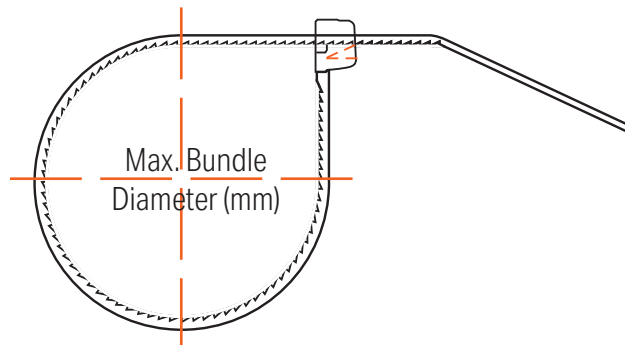
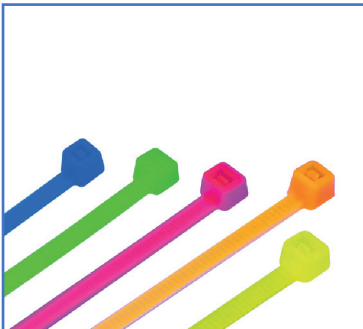

# Cable Ties

## Standard Fluorescent

Item No.	Colour	Width W (mm)	Thickness (mm)	Length L (mm)	Max. Bundle Diameter (mm)	Min. Tensile Strength (kg)
TR5F-BLUE	Fluorescent Blue	4.8	1.35	203	52	22
TR5F-GREEN	Fluorescent Green	4.8	1.35	203	52	22
TR5F-ORANGE	Fluorescent Orange	4.8	1.35	203	52	22
TR5F-PINK	Fluorescent Pink	4.8	1.35	203	52	22
TR5F-YELLOW	Fluorescent Yellow	4.8	1.35	203	52	22
TR8F-BLUE	Fluorescent Blue	4.8	1.5	300	83	22
TR8F-GREEN	Fluorescent Green	4.8	1.5	300	83	22
TR8F-ORANGE	Fluorescent Orange	4.8	1.5	300	83	22
TR8F-PINK	Fluorescent Pink	4.8	1.5	300	83	22
TR8F-YELLOW	Fluorescent Yellow	4.8	1.5	300	83	22
TR10F-BLUE	Fluorescent Blue	4.8	1.5	368	105	22
TR10F-GREEN	Fluorescent Green	4.8	1.5	368	105	22
TR10F-ORANGE	Fluorescent Orange	4.8	1.5	368	105	22
TR10F-PINK	Fluorescent Pink	4.8	1.5	368	105	22
TR10F-YELLOW	Fluorescent Yellow	4.8	1.5	368	105	22

### STORAGE AND USAGE OF NYLON CABLE TIES

BEAL UK cable ties are made from high quality Nylon 66 resin. Moisture absorption is an essential factor for this material to retain its strength and maintain optimal performance. To this end, it is important for the cable ties to be kept in a sealed package wherever possible.

Below are some helpful storage suggestions:

1. The ideal storage temperature is around 23°C with the humidity over 50%.
2. Do not open the bag before use. Please try to finish the whole package of cable ties shortly after opening or reseal the bag until you are ready to use again.
3. Do not expose directly under sunlight (except UV weather resistant cable ties).
4. Avoid storing cable ties close to warm objects (such as heaters).